



Maximum permissible loads in kg:

DIN 580 - C15
 DIN 582 - C15

	 for 1 bolt firmly tightened	 for 2 bolts overall	
	DIN	DIN	
M			
(6)	70	50	
8	140	95	
10	230	170	
12	340	240	
(14)	490	340	
16	700	500	
20	1 200	830	
(22)	1 500	1 050	
24	1 800	1 270	
(27)	2 500	1 650	
30	3 600	2 600	
(33)	4 300	3 200	
36	5 100	3 700	
(39)	6 100	4 300	
42	7 000	5 000	
(45)	8 000	5 500	
48	8 600	6 100	
(52)	9 900	7 300	
56	11 500	8 300	
64	16 000	11 000	
72	21 000	15 000	

C15

Lifting eye bolts, steel
forged and annealed

DIN 580

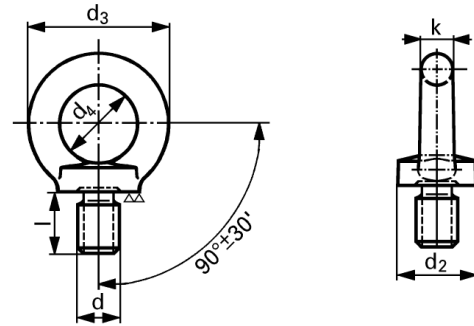

ISO 3266

d	d2	d3	d4	l	k	plain		zinc plated	
						10	100	10	100
quantity						10	100	10	100
M									
(6)	20	28	16	13	7	216.-	175.-	244.-	192.-
8	20	36	20	13	8	206.-	159.-	224.-	186.-
10	25	45	25	17	10	266.-	218.-	306.-	237.-
12	30	54	30	20,5	12	338.-	276.-	372.-	304.-
(14)	35	63	35	27	14	540.-	425.-	605.-	480.-
16	35	63	35	27	14	480.-	378.-	540.-	440.-
18	40	72	40	30	16	695.-	565.-	792.-	650.-
20	40	72	40	30	16	635.-	515.-	760.-	620.-
(22)	45	81	45	35	18	1440.-	1180.-	1760.-	1330.-
24	50	90	50	36	20	1270.-	1050.-	1670.-	1200.-
(27)	50	90	50	36	20	2580.-	2130.-	2900.-	2270.-
quantity						1	10	1	10
30	65	108	60	45	24	2375.-	1960.-	3180.-	2600.-
(33)	65	108	60	45	24			3950.-	3130.-
36	75	126	70	54	28	3538.-	2900.-	4130.-	3430.-
(39)	75	126	70	54	28	5780.-	4640.-		
42	85	144	80	63	32	5600.-	4530.-	7680.-	6340.-
(45)	85	144	80	63	32	8580.-	7100.-		
48	100	166	90	68	38	8870.-	7350.-	10500.-	8910.-
(52)	100	166	90	68	38	18250.-	14040.-	21000.-	16500.-
56	110	184	100	78	42	19660.-	16020.-		
64	120	206	110	90	48	26000.-	21320.-		
72	150	260	140	100	60	82990.-	67600.-		
80	170	296	160	112	68	57040.-	19600.-		

C15

Lifting eye nuts, steel
forged and annealed

DIN 582

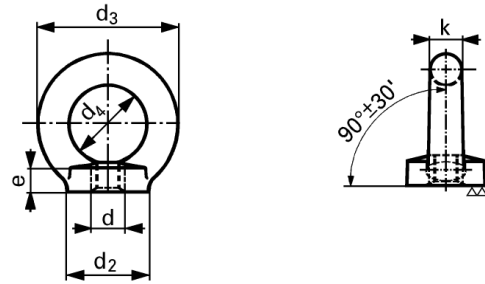

d	d2	d3	d4	e	k	plain		zinc plated	
						10	100	10	100
quantity						10	100	10	100
M									
(6)	20	36	20	8,5	7	296.-	244.-	310.-	254.-
8	20	36	20	8,5	8	229.-	192.-	244.-	205.-
10	25	45	25	10	10	286.-	234.-	320.-	256.-
12	30	54	30	11	12	354.-	288.-	405.-	340.-
(14)	35	63	35	13	14	470.-	384.-	530.-	425.-
16	35	63	35	13	14	475.-	386.-	545.-	450.-
(18)	40	72	40	16	16	765.-	610.-	810.-	650.-
20	40	72	40	16	16	685.-	565.-	735.-	615.-
(22)	45	81	45	18	18	1510.-	1250.-	1630.-	1340.-
24	50	90	50	20	20	1310.-	1150.-	1500.-	1300.-
(27)	50	90	50	20	20	3270.-	2630.-	3560.-	2860.-
quantity						1	10	1	10
30	65	108	60	25	24	2820.-	2270.-	3150.-	2560.-
36	75	126	70	30	28	4060.-	3270.-	6180.-	5600.-
42	85	144	80	35	32	7580.-	6100.-		
48	100	166	90	40	38	11330.-	9120.-		
56	110	184	100	45	42	28080.-	23460.-		
64	120	206	110	50	48	34320.-	28600.-		

T-head bolts, steel

K 214 for rail type 2, 3, 4

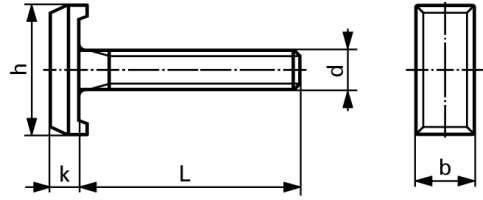

Zinc plated

d	M 10		M 12		M 16		
h	+2	36	36	36	36		
b	±1	11	14	14	18		
k	±0,5	8	9	9	11		
L	quantity	100	1000	100	1000	100	1000
25		190.-	164.-				
30		192.-	167.-	206.-	179.-	214.-	186.-
35		195.-	170.-	211.-	183.-	217.-	190.-
40		197.-	172.-	214.-	186.-	223.-	194.-
45		228.-	198.-	240.-	208.-		
50		242.-	211.-	256.-	223.-	250.-	223.-
60		250.-	223.-	276.-	240.-	252.-	225.-
70				298.-	260.-	356.-	310.-
80				362.-	320.-	378.-	326.-
90				400.-	362.-	430.-	384.-
100				475.-	430.-	500.-	455.-
with nuts DIN 934		+ 10.80	+ 7.80	+ 13.80	+ 12.-	+ 26.-	+ 19.30

T-head bolts, steel

K 215 for type 5

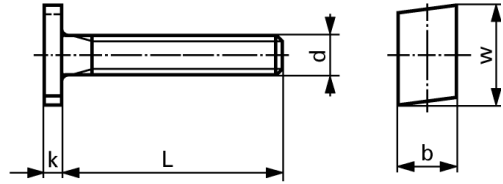

Zinc plated

d	M 8	M 10	
w +2	23,5	23,5	
b ±1	10	10	
k ±0,5	3,5	3,5	
L quantity	100	100	
20	254.-		
25	236.-	294.-	
30	296.-	328.-	
35	300.-		
40	304.-	342.-	
50	350.-	368.-	
60		375.-	
80	270.-		
with nuts DIN 934	+ 7.-	+ 10.80	

T-head bolts, steel

K 216 for rail type 6

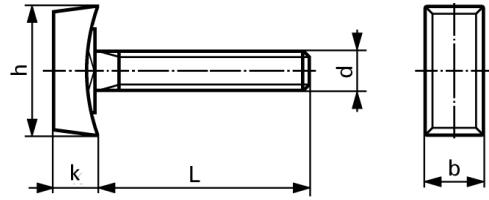

Zinc plated

d		M 10	M 12	M 16	
h	+2	25	25	25	
b	±1	12	14	17	
k	±1	10	11	12	
L	quantity	100	100	100	
	25	252.-			
	30	288.-	296.-		
	40	320.-	320.-	348.-	
	50		352.-	376.-	
	100		380.-		
with nuts DIN 934		+ 10.80	+ 13.80	+ 26.-	

U-bolts round bent, steel
with 2 hex nuts

MU K 212

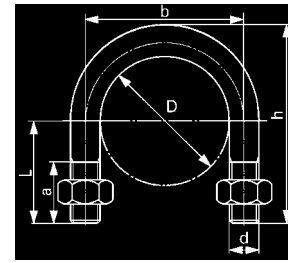

d x D	NW in mm	NW in inch	b	h	L	zinc plated	
						100	1000
quantity							
M							
8 x 22	15	1 ¹ / ₄₂ "	30	44	25	119.-	91.50
8 x 27	20	3 ¹ / ₄₄ "	35	49,5	28	124.-	97.-
8 x 34	25	1 "	42	57	32	130.-	102.-
10 x 44	32	1 ¹¹ / ₄₄ "	54	68	36	161.-	134.-
10 x 50	40	1 ¹¹ / ₄₂ "	60	75	40	167.-	139.-
10 x 62	50	2 "	72	88	47	187.-	162.-
10 x 78	65	2 ¹¹ / ₄₂ "	88	104	55	272.-	238.-
10 x 92	80	3 "	102	116	60	280.-	244.-
10 x 116	100	4 "	126	140	72	400.-	350.-

Turnbuckles, steel

DIN 1480

- DIN 1480-E with 2 eye bolts
- DIN 1480-H with 2 hook bolts
- DIN 1480-M with 1 eye bolt and 1 hook bolt
- DIN 1480-A with 2 weld studs

d1	DIN 1480		DIN 1480-E/H/M		DIN 1480-A	
	zinc plated		zinc plated		black	
quantity	10	100	10	100	10	100
M						
6	410.-	341.-	720.-	580.-	540.-	436.-
8	445.-	360.-	790.-	635.-	585.-	468.-
10	570.-	445.-	980.-	780.-	705.-	567.-
12	710.-	570.-	1160.-	915.-	835.-	666.-
14	855.-	660.-	1340.-	1080.-	1020.-	830.-
16	1160.-	920.-	1860.-	1485.-	1340.-	1070.-
20	1870.-	1495.-	3090.-	2450.-	2160.-	1730.-
quantity	1	10	1	10	1	10
24	3580.-	2860.-	5910.-	4730.-	3950.-	3160.-
30	4770.-	3810.-	9390.-	7150.-	5370.-	4300.-
36	8150.-	6520.-			9050.-	7240.-
42	13450.-	10750.-			15790.-	11960.-

Turnbuckles, steel

DIN 1480

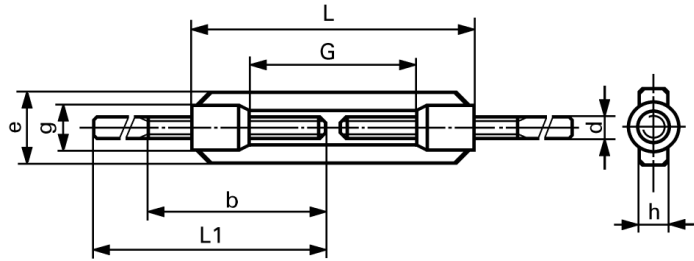

d	L	G	e	g	h	b	L1	adjustment	
					min.				
								mm	
M									
6	110	86	19	12	6	65	120	80	
8	110	80	23	15	8	65	120	75	
10	125	89	30	18	9	75	150	85	
12	125	83	34	21	11	75	150	80	
14	140	90	36	23	12	80	170	90	
16	170	116	42	27	14	100	200	110	
20	200	132	52	34	17	120	220	130	
24	255	177	60	39	20	150	260	170	
30	255	165	74	45	23	150	260	160	
36	295	185	86	55	28	180	300	180	
42	330	204	104	63	32	200	350	200	